

WEC news

GROUP

Issue 12

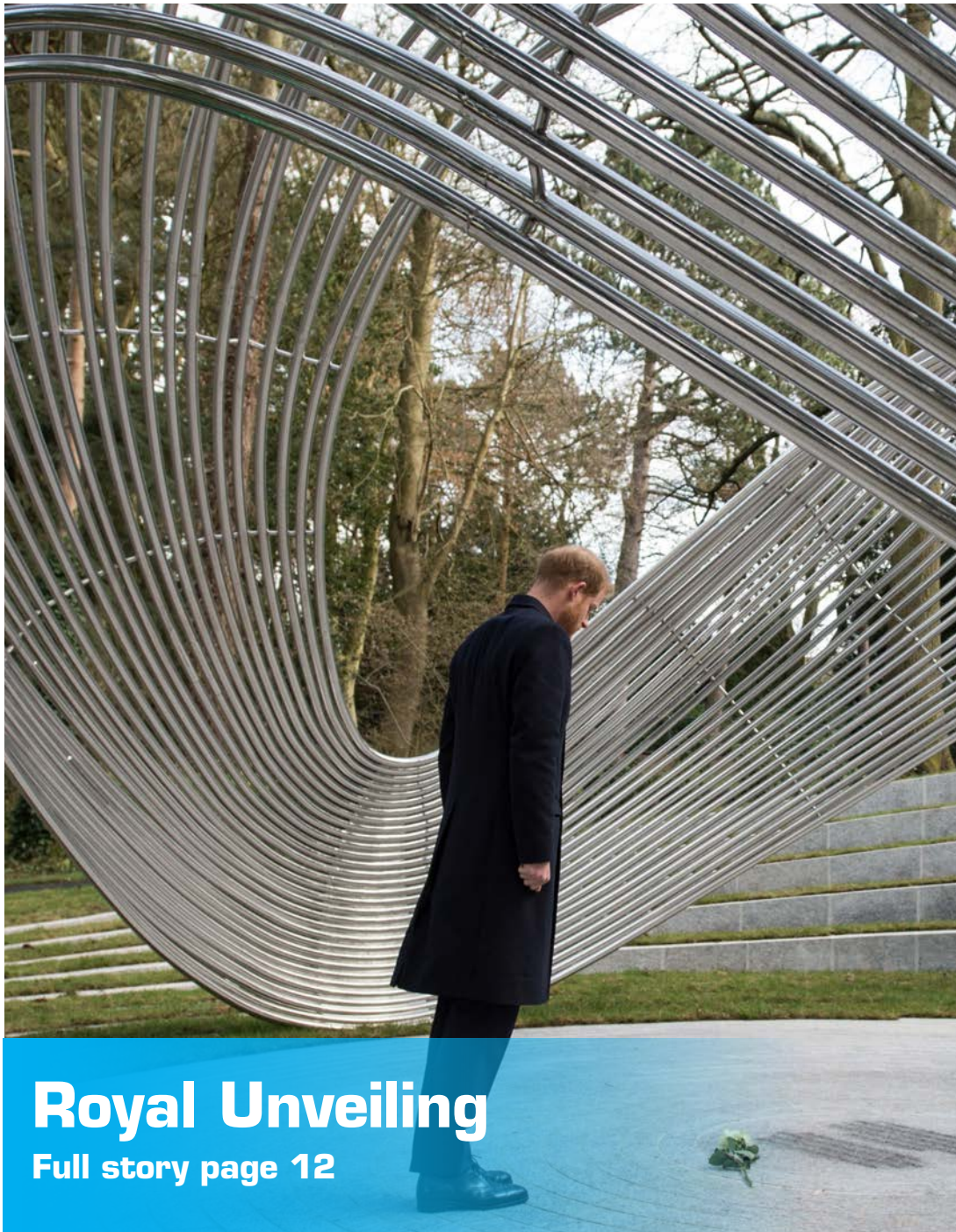

Royal Unveiling

Full story page 12



Apprentice of the Year Awards 2018

Page 16



WEC Group turns 40!

Page 2



North West Large Employer of the Year

Page 15



Team UK selection for WorldSkills

Page 9

www.wec-group.com

Message from the board...



Steve Hartley, Managing Director

2018 has been another record year for WEC Group despite tough market conditions and uncertainty. The manufacturing industry has so far proven resilient and we are confident that 2019 will see further growth for the company as a whole

A £6m investment plan is currently under way to pave the way for future success and help us retain our competitive edge (more can be read about this on page 4-5).

2019 is a special year for WEC Group as it marks the 40th year of the company being in business. We're extremely proud of this achievement and to have seen the company grow in such a sustainable way over the years.

We would like to say a big thank you to all staff, many of whom have been with us since the very early days of WEC Group.

2019 is already shaping up to be another year to remember!

The BIG 40

We are really proud to have reached yet another huge milestone!!

Whilst WEC Group could be summarised by a long list of bold moves and success stories, its origins, however, were modest. As we celebrate a whopping 40 years in business, we take some time to reflect on some of our past achievements and successes.

The Welding Engineering Company was originally set up in 1979 and our success story is a testament of the merits of Blackburn with Darwen's town crest moto "arte et labore" - "by skill and labour".

Those of you who have been with us since the early days will know that it has been a bumpy road at times but with your help, we've managed to grow the business in a sustainable way, propelling us to new heights to take our place as one of the UK's leading manufacturing businesses.

The past 10 years have been especially successful and have seen us grow from 270 staff to well over 900 today thanks to constant reinvestments in technology and successful new business ventures. Once again, we would like to thank all of our staff for their continued support and dedication. Here's to the next 10 years!



www.wec-group.com

From humble beginnings on to new heights

1979

The Welding Engineering Company was founded by Steve Hartley and Ross Place in a 1000 sq. ft. makeshift shed in Darwen



1998

WEC acquires its first laser cutting machine and sets up a new specialist division, Laser Engineering UK



1983

Following expansion, the company was approached to design and manufacture one of the first CCTV camera towers, leading to the set up of WEC Camera Mounting Solutions



2004

Following steady growth and with now over 100 staff and 3 specialist divisions, the company decides to rebrand from W.E.C. Ltd to WEC Group Ltd

2008

A new WEC Special Projects division is set up with a focus on stainless steel fabrication, as well as commercial diving chambers, street furniture and volume production work



2006

WEC acquires local precision engineering company (Precision Engineers Rishton) and later rebrands the company Hi-Spec CNC



2006

The WEC Welding & Engineering Academy opens its doors in a move aimed at bridging the skills gap and create new growth opportunities



2005

m-tec was set up to facilitate the demand for bespoke stainless steel architectural metalwork and public art

2008

WEC acquires Knowsley based laser cutting company 5750 Components Ltd, increasing staff count to over 250



2010

WEC acquires small local fabrication company and integrate them into our Darwen workforce increasing our total staff count to over 300



2010

WEC acquires Blackburn based Nutter Aircrafts, a precision engineering business established in 1939 with a highly qualified workforce who join ranks with Hi-Spec CNC



2011

WEC opens a new specialist factory in Sherburn-in-Elmet near Leeds to manufacture bus frames and chassis for local manufacturer Optare

2015

WEC acquires the assets of MTL Group in Rotherham saving 133 jobs and increasing our staff count to over 600. MTL Advanced Ltd is set up, paving the way for further growth for the Group.



2013

A second factory is purchased in Blackburn to house our new waterjet cutting division WECjet Ltd, and substantially increase our profiling capabilities



2015



2015

A new powder coating division is set up at our Head Office in Darwen, with a fully automated inline system, bringing our sheet metal finishing work in-house



2012

Our Hi-Spec CNC and Nutter Aircrafts divisions are relocated to a purpose built 33,000 sq. ft. factory at Walker Park in Blackburn and merged into a single entity - WEC Machining

2016

A new sales office based in Stafford is opened to increase our geographic reach and promote our capabilities to customers in the Midlands and the South



2016

WEC acquires laser cutting & fabrication specialists HTA Group in Coventry, adding an extra 130 staff to our headcount and bringing us over the 800 mark



2019



2016

A new division is set up at MTL Advanced to promote MTL's profiling and sheet metal capabilities to a wider customer base



2017

5750 relocates to new premises in Knowsley on the back of a £3m investment which leads to a massive increase in laser cutting & fabrication capacity

WEC Unveils £6 Million Group-wide Expansion and Investment Plans for 2019



LT8.10 Fibre Tube Laser

To fuel our growth and retain our position as one of the UK's leading manufacturing businesses, an ambitious £6 million investment plan has been unveiled.

On the back of another record year for 5750 Components Limited, which has seen their turnover almost double since their move to new premises in 2017, our Knowsley based division will be the first to benefit from these investment plans with a further £1m investment already under way to acquire their first tube laser in a move aimed at mirroring our Darwen site's very successful business model.

The new Adige LT8.10 Fibre will be commissioned in April / May 2019 and will allow us to cut tubes, box section, and special shaped tubes or open sections up to 8.5m in length and 240mm diameter which is a significant increase compared to our current offering.

The machine will come fully equipped with an improved 3D tilting head which makes it possible to do ($\pm 45^\circ$) chamfers and other complex cutting patterns including weld prep cuts in thick walled tubes.

Meanwhile, a similar Adige LT8.10 fibre laser with step loader will also be installed at our Laser Engineering site in Darwen later in the year alongside three 10kw fibre lasers as part of a further £4m investment due to take place in Q3 or Q4 of 2019.

LT8.10 FIBER CAPABILITIES

- > capability to cut diameters up to $\text{\O}240\text{mm}$
- > bar weight up to 40 kg/m (30 lb/ft.)
 - > loading length 12.5m
 - > unloading length 8.5m
- > Tilting Axis ($\pm 45^\circ$) for weld preps
- > Ability to process brass, copper & galvanized tubes



Laser Engineering 2.0 - Complete Overhaul for our Technology Centre in Darwen



Our flagship laser cutting facility will benefit from £4m of investments in 2019

It has now been 10 years since we opened our purpose-built laser cutting facility in Darwen with three CO2 Lasers and one of the first tube lasers in the UK.

Rightfully dubbed as “The Technology Centre” at the time, our new facility and avant-garde machinery allowed us to grow into one of the most successful laser cutting operations in Britain, increasing our total number of lasers at the Darwen site from 4 to 7 in just a couple of years.

Technology has progressed at a rapid pace over the past 10 years, especially with the development



3 new 10kw fibre lasers will also be installed in Darwen, increasing cutting capacity by over 30%

of fibre laser technology, and we have now decided to retire our aging CO2 flat bed lasers and replace them with the very latest 10kw fibre lasers which have been trialled at our 5750 Components and MTL Advanced sites over the past year.

This move will see us massively reduce our carbon footprint and gain an impressive 33% in capacity which will allow us to retain a competitive edge and continue servicing our growing customer base.



Construction of the new roof for our Laser Yard started in December 2018

Major works are also currently under way for the building of a roof for the main yard at Laser Engineering which will create a covered working space for our dispatch team and improve logistics and storage space in all weather conditions.

Massive Recruitment Drive at MTL Advanced

As MTL Advanced continues to grow, be sure to take advantage of our Refer a Friend scheme.

2019 is already shaping up to be one of MTL Advanced's busiest years to date and on the back of a series of large contracts, we are now looking to create a further 50 new jobs throughout 2019 to allow us to cope with the increased demand.

With all our production bays operating almost at capacity, we have now initiated a major recruitment drive at all levels of the business including a further 20 apprenticeship vacancies starting in September.

As a company, MTL Advanced is increasing its focus on the development of the next generation of

skilled personnel and this year will be taking on the largest number of apprentices to date.

In addition to the upcoming apprenticeship vacancies, we are now on the lookout for skilled welders/fabricators, press brake operators, project engineers, sales estimators, laser operators, etc to start as soon as possible in order to fuel MTL's continued success.

To that effect, we would like to remind all of our staff about our very successful Refer a Friend scheme whereby you can earn up to £1000 when someone you referred completes 12 months of employment with us. For further information about how the Refer a Friend scheme works and how you can be involved, please contact HR (recruitment@wecl.co.uk).



mtl

**LOOKING TO
PROGRESS IN YOUR
CAREER?**

**APPLY NOW!
WWW.MTLADV.COM**

**PLACES IN ROTHERHAM
WITH IMMEDIATE START**

**NOW RECRUITING SKILLED WELDERS & FABRICATORS,
PRESSBRAKE OPERATORS, ESTIMATORS, ETC**

www.mtladv.com/careers

New Powder Coating Plant for HTA Group



HTA Group extend their comprehensive services with a brand new state-of-the-art in-house powder coating plant.

The £500,000 investment in the latest powder coating technology allows HTA Group to offer a high-end powder coating service across a wide range of industries including rail, automotive, nuclear and aerospace.

The new system installed at the HTA site in Coventry mirrors the setup at our Darwen site and has been carefully selected from the Swiss manufacturer Gema.

The system is equipped with automatic reciprocators, a 90% recovery system and 4 stage in-line pre-treatment plant.

We're proud to be one of the very few companies in the UK that now offers our whole range of services in-house. The new powder coating plant allows us to do everything under one roof which means improved lead times and reduced transport costs. It also puts us in a strong position to establish additional partnerships with First Tiers and OEMs.

With this new addition to the in-house services available at HTA Group, we look forward to now being able to pursue further business opportunities on a subcontract basis.

Contract Update

Deliveries to site have now started for our Aero Engine Test Bed contract for Rolls-Royce in Derby

The past few months have been incredibly busy at our WEC Fabrication site on Spring Vale Road in Darwen, as we worked our way through a large contract to supply large fabrications for the whole length of the world's largest engine test bed facility currently being set up at the Derby site of Rolls-Royce.

A big well done to all those involved!



www.wec-group.com

CCTV Export Success through 2018

It has been another big year for our CCTV team with a 59% increase in export sales compared to 2017.

The export market has been an increasingly important part of our CCTV division's growth plans over the past few years, and we've recently once again attended the Intersec tradeshow in Dubai to promote the merits of UK manufacturing and develop new business partnerships in the booming Middle East market.

The hard work of all our CCTV team has paid off and we are now a very well known name in the area and are currently tendering for various high profile projects, including the 2022 Qatar World Cup.



New Website - Coming Soon

A lot of work is also currently being done in the background to prepare for the launch of a new e-commerce website which will allow customers to purchase our stock products online in the most straightforward and user friendly manner.

This should in turn help increase our international market reach. Watch this space!

New General Manager for WEC CCTV

We would like to congratulate John Whittle who was recently appointed as the new General Manager of our CCTV division in Darwen.

After 15 years' service to the company, the position is well earned and we would like to take this opportunity to wish John all the best in his new role!



www.wec.uk.net

Building Bridges

Another beautiful project secured for m-tec as they win a multi-million pound contract to fabricate steel bridge over Lake Ullswater in Cumbria.

m-tec, the architectural division of the wider WEC Group Ltd, have won a new multi-million pound contract to fabricate a stainless steel bridge for the village of Pooley Bridge in the Lake District.

The bridge components will be profiled by our DNA Metalwork division and then fabricated by a team of dedicated welder/fabricators from m-tec in Darwen. The structure is an open-spandrel arch bridge design with a 40m span and will be crafted from 110 tonnes of Duplex 2205 stainless steel as well as concrete. Once completed, it will be used for pedestrian and single lane motor traffic to cross the river Eamont.



Image courtesy of Knight Architects

m-tec have already been involved in numerous projects including the design, manufacture and installation of the Mead's Reach Bridge at Temple Quay in Bristol. To this end, m-tec were selected for the Pooley Bridge project as the bridge's structure is extremely difficult to manufacture and the company has a proven skill level and ability to deliver complex stainless steel fabrications with value engineering. Well done to Tom Elliot, David Summerlin and everyone involved.

WEC's Very Own World Welding Superstar!

Tyler Atkinson qualifies to be part of Team UK in Kazan

After two years of bootcamp training sessions, assessments and competitions, our very own "Welding Superstar" has officially been announced to represent the United Kingdom in Construction Metal Work at the 'skills olympics' held later this year in Kazan, Russia.

Tyler was first identified for Team UK selection following his success at the WorldSkills UK competition in 2017 where he was able to secure a silver medal.

Since his medal win, he has been attending various bootcamp sessions, events and competitions in order to secure his place in the final Team UK and go on to compete globally in Kazan. Tyler has also recently been featured on BBC North West Tonight and BBC Radio Lancashire in light of his fantastic accomplishment.

He is now due to attend a ceremony of celebration in London and meet the queen with his fellow Team UK competitors from other various disciplines including everything from Hairdressing to Joinery.

We are incredibly proud of Tyler's achievements and would like to wish him all the best in the upcoming competition and flying the flag for the UK!



**Keep up to date with our company news by following us on:
Twitter (@wecgroup ltd) or Facebook (fb.com/wecgroup ltd)**

Great Feedback for Clarendon

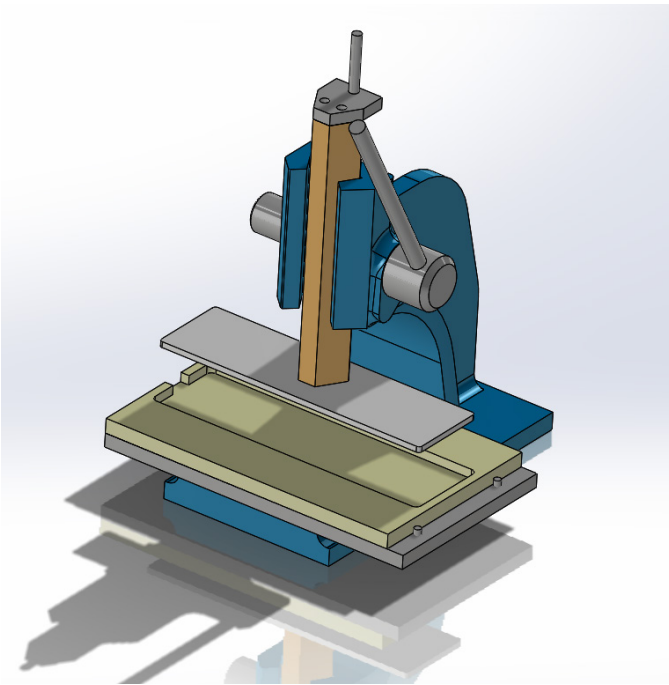

Founder of Loving Humanity charity, Amy Peake, approached Clarendon for assistance with developing a press and was delighted with the end product.

Loving Humanity is a non-profit organisation, which was created out of Amy's desire to support the Syrian refugees. Their focus is to buy and install machines that make feminine hygiene products for the girls and women currently residing within a nearby refugee camp.

For more information about this charity, please visit their official website: <http://lovinghumanity.org.uk/>

Quality in 2018

2018 was an interesting and very successful year for Quality.

New contracts have been gained with more stringent requirements on quality and documentation.

Project Management has been implemented as a process with regular reviews along the process. This ensures a quality product has been produced, verified and delivered on time to the customer.

Throughout 2018, Quality became more prevalent on shop floors in helping production with the validation of the product throughout the processes involved. Any deviation can then be corrected before the product is finished.

2019 is coming with new challenges including raising our performance level against new targets in all processes and on reinforcing root cause analysis in order to understand where the processes need improving.



Re-fresher training is also planned for the near future in order to raise awareness and knowledge amongst our Quality Team.

In summary, the Quality Team will be prepared and more committed to continue their efforts with improved tools.

AS9100 Aerospace Recertification

We are delighted to announce that the AS/EN 9100 aerospace accreditation for WEC Machining has been renewed after 3 hard months of BSI "marathon audits".

Well done to the System Quality and Machining teams for your hard work and commitment to achieve the re-certification. Achieving this level of certification demonstrates our commitment towards continuous improvement of our products and services to meet and excel international standards.

www.wec-group.com

m-tec Fabricate Stunning Memorial for Birmingham Pub Bombing Victims



The memorial project for the victims of the Birmingham Pub Bombings of 1974 has now been unveiled at Birmingham New Street Station in a moving ceremony to mark the 44th anniversary of the attack.

Working in collaboration with Network Rail, the sculpture was designed by artist Anuradha (Anu) Patel and was then manufactured and installed over the course of 24 weeks by our architectural division, m-tec.

The memorial consists of three 15ft trees made of both stainless steel and corten/weathering steel to offer different textures and finishes. The seven leaves of each of these trees have been designed to bear the names of the 21 victims along with their ages. These details were laser cut into the underside of the steel leaves to act as a lasting memory for their friends and family. Alongside the main sculptures, we fabricated three matching stainless steel and iroko wood planters

With previous memorial projects including a World War I memorial arch in Folkestone and a Spitfire memorial in Darwen, Tom Elliot, Divisional Manager of m-tec, said: "We are especially proud to have been involved with this key project and to bring Anu's vision to life. Now fully installed and unveiled, the sculpture proves to be a stunning tribute to those who lost their lives in the attack".

Speaking before a multi-faith service to unveil the memorial, its designer, local artist Anuradha Patel, said she hoped its prominent position would provide comfort to relatives and help inform future generations about the atrocities.



A big well done to all our staff from Special Projects and Laser Engineering who were involved with this very high profile job.

HRH Prince Harry unveils m-tec latest project



m-tec and our Special Projects team have produced an awe-inspiring Memorial in honour of the British Victims of Sousse and Bardo Tunisia Terror attacks.

Erected in the memory of the 31 British nationals who died as a result of the terrorist attacks in Sousse in June 2015 and the Bardo Museum attack in March 2015, the 'Infinite Wave' sculpture was unveiled by the Duke of Sussex in a ceremony at the sculpture's location in Birmingham's Cannon Park on Monday 4th March.

The Duke of Sussex was joined by 300 guests, which included families of the victims and those caught up in both attacks. The ceremony, led by BBC newsreader Ben Brown, who reported from Sousse soon after the terrorist attacks in June 2015, included readings from families of the victims and music from a the Birmingham Bach Choir.



M-tec were approached to fabricate the complex sculpture which was designed by George King Architects. Taking approximately 4 months to fabricate, the design of the sculpture is a tubular design made from 316 stainless steel schedule tubes.

It was fabricated in three sections using specially designed jigs— two end sections that were welded and polished as a complete assembly and a middle section that was a series of individual polished tubes that connected the two ends.

**Keep up to date with our company news by following us on:
Twitter (@wecgroupLtd) or Facebook (fb.com/wecgroupLtd)**

The sculpture was a particularly complex design due to the fact that no two tubes were identical to each other. Other challenges included maintaining the structural integrity of the fabrication, the need to transport and install the sections without causing any damage to the sculpture because of the irregular shape of each section, the positioning on site so that the middle sections fitted correctly and also the polishing of the sculpture both in the workshop and on site to achieve a mirror finish.

George King, Principal of George King Architects said: "Throughout the design and construction process we have been acutely aware of the significance that this memorial has for the families who have lost loved ones, the survivors and the wider community. We put them and their experiences very much at the heart of the design concept.

"Together with our team of expert consultants, fabricators and contractors, we have focused on translating our unique design into reality with a focus on craftsmanship, quality and fine detailing in order to create a meaningful place of reflection and contemplation within the beautiful setting of Cannon Hill Park."

"We are extremely proud of our team whose hard work and dedication over the past two years has delivered a beautiful and poignant memorial that we hope will have a special place in people's hearts for many years to come."

Tom Elliot, Divisional Manager at m-tec, said: "We are honoured to have played our part in the creation of this very special memorial for the terror attacks in Tunisia. The sculpture is a stunning piece of design work and a fitting tribute to everyone affected. It was such a pleasure to attend the moving ceremony that was held at the unveiling and to have the meaningful sculpture."

This marks the second of our sculptures to be unveiled by HRH Prince Harry, the first of which being the Folkestone WW1 Memorial Arch which was unveiled in 2014.

We would like to take this opportunity to thank everyone who was involved in this project!



Back in the Saddle

Working with a local charity, our WEC Group Academy apprentices fixed specialised hand powered bike.



Our apprentices and Training & Development Manager, Kris Mercer received big thanks from Blackburn charity, Sporting NRG for repairing a bike designed for use by disabled riders.



The bike, belonging to a local young man named Alex, was fixed at our Darwen site by our apprentices.

Continuing our work with the charity, we have also been working on a Boccia bowling frame to assist a young boy with his game.

We look forward to completing further projects with NRG in the near future and would like to thank everyone involved!

Engineers of the Future

WEC Group was proud to be a part of the Year of Engineering campaign.



To this end, WEC employed various measures across 2018 to help inspire the next generation of engineers.

Every year local schools are invited to visit our manufacturing site to gain an insight into the work we do. Most recently, it was our pleasure to invite the students of Pleckgate High School in Blackburn to tour our site in Darwen and allow them to explore the many processes required to create a final product.

For the first time, WEC Group also made its appearance at the WorldSkillsLIVE 2018 show. Here, alongside promotional material for our Clarendon by WEC division, we used the opportunity to advertise our award-winning Training School to young people from across the nation.

We have also featured numerous posts across our social media platforms in a campaign to inspire potential applicants and engineers. These posts included infographics from the official Year of Engineering campaign as well as a quotographic featuring one of our talented apprentices and the adoption of the official hashtags such as #YearofEngineering and #inspire and engineer in order to join the campaign conversation.

Despite the official campaign having finished, we hope to continue inspiring prospective engineers throughout the coming year indefinitely.

Visit the official website for more information about the campaign: yearofengineering.gov.uk

Keep up to date with our company news by following us on:
Twitter (@wecgroup ltd) or Facebook (fb.com/wecgroup ltd)

WEC Group wins North West Large Employer of the Year 2018



We are delighted to have won The Royal Navy Award for Large Employer of the Year at the North West Regional National Apprenticeship Awards 2018.

Beating many blue-chip OEMs and larger organizations on the day to win the award, this will be the third time that WEC Group has won the award in the past 5 years.

We have since gone on to represent the North West region and attend the National Finals on 28th November in London. Here, we were awarded Highly Commended in the Royal Navy Award for Large Employer of the Year 2018.

Kris Mercer, Training & Development Manager

at WEC Group said: “We are delighted that our dedication to our apprenticeship programme has once again been recognised. We are truly passionate about our apprentices and harnessing their talent to inspire further generations.

“We recognise that offering Apprenticeships is vital to our future growth and closing the Engineering skills gap and we are very proud that we now have some of the best apprentices in the UK and the skills to compete internationally.”

In light of this success, we would like to express our gratitude to everyone who continues to make our apprenticeships a success. And thank you, most of all, to our talented apprentices themselves.



 **Apprenticeships**
National Awards 2018
Regional Winner

Keep up to date with our company news by following us on:
Twitter (@wecgroup ltd) or Facebook (fb.com/wecgroup ltd)

WEC APPRENTICE OF THE YEAR AWARDS 2018



We celebrated the success of our talented apprentices at our annual Apprentice of the Year Awards 2018.

The awards evening took place on Thursday 29th November at the Red Rose Suite in Ewood Park, Blackburn. With esteemed guests including: the Deputy Mayor of Blackburn Cllr Jim Shorrocks; Deputy Consort Mr Mark Joyce; Mayor Roy Davies; EUR ING Chris Eady CENG FWELDI; and the Group's creative partner for the Festival of Making, David Murphy, the event celebrated the apprentices' success over the past year.

Students from our welding and fabrication, CNC machining, technical production engineering and office-based apprenticeships across the various sites within the Group were presented with awards based on their commitment and academic achievements as well as welding, machining and technical production engineering excellence. Those who have successfully completed their five year course were also presented with a special award of recognition.

George Hawkey, one of our talented welding and fabrication apprentices in Darwen, was crowned this year's WEC Group Apprentice of the Year after being recognised for his excellent work ethic and outstanding portfolio of work which perfectly demonstrates his ability to produce work to the highest standards.

The MTL Apprentice of the Year title was awarded to Luke James. Another welding and fabrication apprentice, Luke has won the award after receiving nothing but praise from his superiors about his demonstrable talent for engineering and his ability to thrive during the most demanding tasks.

Kris Mercer, our Training & Development Manager said: "We have an exceptional bunch of apprentices working for us currently and we are very proud of everything that they continue to achieve. To this end, we wish to reward them for all of their hard work during their time here and invite them to celebrate their success with their families, friends and loved ones."

Well done to all of our apprentices!

See more photos at: [facebook.com/wecacademy](https://www.facebook.com/wecacademy)

OUR WINNERS...

ACADEMIC ACHIEVEMENT AWARD



JAMES SEDDON

APPRENTICE OF THE YEAR

**GEORGE HAWKEY (WEC)
& LUKE JAMES (MTL)**



WELDING EXCELLENCE AWARD



MATHEW WALSH

MACHINING EXCELLENCE AWARD



SHAMAS HAROON

COMMITMENT AWARD



ALEX JEPSON & JOSH KEEN

TECHNICAL PRODUCTION ENGINEERING EXCELLENCE AWARD



THOMAS RIGBY

WorldSkills UK Finals and Bronze Medal Win for Sam

Congratulations to our five incredible apprentices who made it to the finals of WorldSkills UK 2018. Further congratulations are in order for Sam Carter who went on to win a bronze medal at the event.



With the qualification taking place earlier in the year, Robert Caldwell, Matthew Caswell, James Seddon, Sam Carter and Callum Bullough were able to qualify in the Top 10 in their events and went on to proudly represent WEC Group at the national finals.



The WorldSkillsUK 2018 finals took place at the NEC in Birmingham in November 2018. During the three day event, our apprentices faced gruelling challenges in order to compete in one of the following events: Construction Metalwork or, a WEC Group first, Sheet Metalwork.

Sam Carter, a welding/fabrication apprentice at our Training Academy in Darwen, was able to perform exceptionally under pressure and was therefore awarded a bronze medal for his effort.



We are incredibly proud of Sam's achievement as he now joins the WEC Group's WorldSkills Wall of Fame alongside our 6 previous medal winners.

The Group's consistent success at the WorldSkills UK event is testament to the high level of training which is provided at our Training Academy.

Kris Mercer, WEC Group Training and Development Manager, said: "Our apprentices performed incredibly well at this year's competition and we were very proud to have so many of our apprentices qualify in the top 10. The competition was particularly fierce this year and the challenge which was set was especially difficult. As a result, we are over the moon for Sam and his medal win and now look forward to hopefully winning further medals in 2019"



Fire it Up Campaign!

We are delighted to support the brand new #FireItUp campaign run by the National Apprenticeship Service.

National Apprentice Week 2019 began on 4 March and to mark the occasion, we donned special edition Fire It Up cover photos across our social media platforms and posted a variety of content to engage and inspire young engineers or prospective apprentices.

Our content included apprentice biographies, quotes, live laser cutting footage, career events and more. Thank you to each of the apprentices that got involved and gave us an insight into their apprenticeship journey with us.

We continue to attend various local career fairs and events throughout the year at local schools, colleges and academies as we recruit for our September intake of apprentices. If you know anyone who may be interested, we are now looking for apprentices to join us in Darwen, Rotherham, Sherburn in Elmet and one apprentice for our Blackburn site. Be sure to spread the word!



Awarding Excellence Across the Group

Welding Excellence Award

We would like to congratulate all the recent winners of our welding excellence award which is based on an individual's outstanding commitment and workmanship, as well as recognising their consistently high-quality work.



Aug 2018
Craig Gardner



Sep 2018
Matt Walsh



Oct 2018
Huczko Zbigniew



Nov 2018
Tom Woodburn



Dec 2018
Darren Jackson



Jan 2019
Luis Stevenson



Feb 2019
Lee Galvert

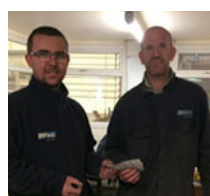

Mar 2019
Howard Fielding



Welder of the Year 2018
Matt Walsh

Keep up to date with our company news by following us on:
Twitter (@wecgroup ltd) or Facebook (fb.com/wecgroup ltd)

Macmillan Coffee Morning 2018

WEC Group staff turned their hand to baking in order to raise money for Macmillan Cancer Support



Thank you to everyone who got involved in our Macmillan Coffee Morning this year.

Your support and generous donations meant that we raised a grand total of £270.84!!

It was a brilliant team effort and it was amazing to see so many delicious bakes from coffee cake to malteser bites and cupcakes galore.

An extra special thanks goes to our Star Baker for this year, Tracey Callaghan.



WEC Wore it Pink for Breast Cancer Now

Back in October, we were proud to support the national wear it pink campaign.

Donning a limited edition pink logo across our social media platforms and with a group-wide dress down day on 19th October, we were able to support the campaign and raise a fantastic £743.44 for Breast Cancer Now.

Well done to everyone involved and thank you for supporting this great cause close to many of our hearts.

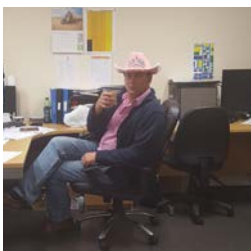

WEC
GROUP



wear it
pink

Keep up to date with our company news by following us on:
Twitter (@wecgroup ltd) or Facebook (fb.com/wecgroup ltd)

Family Fun Day 2018

WEC Group held it's first ever Staff Family Fun Day at AFC Darwen Anchor Ground on 1st September.

**OLIVER'S
NEUROBLASTOMA
APPEAL**

We are very grateful to everyone who came to support the event with their family and friends and can proudly announce that we were able to raise a fantastic £673.50 for Oliver's Appeal on the day. The event included: face painting, bouncy castle, luxury raffle, staff 5-a-side football tournament and much more.

Thank you to all of the local business that kindly donated prizes for our raffle: Astley Bank, Akash, Amalfi, Blackburn Ice Arena, Blackburn Rovers FC, Cin Cin, Dark Horse Hair, Darwen Golf Club, Delicarlo, Dolly's Tea Room, Essence, Happy Daze, Smithhills Farm, Vandas Market Garden, W J Bland and Wood-Sage Outdoor Education.

And thank you to everyone who helped to make the day a great success including AFC Darwen, Belinda John our face painter and to Happily Ever After, Kevin Kearney, DJ Ivan and Eventech for their services. Special thanks also to Olivia in Marketing for coordinating the event.



Reverse Advent Calendar



In collaboration with Lancashire-based company Media Village, we took part in a Reverse Advent Calendar initiative to support Blackburn Foodbank.

Leading up to the festive period, WEC Group signed up to join Media Village's Reverse Advent Calendar alongside many other local businesses to donate as much food as possible to Blackburn foodbank.

Through, emails, posters and intranet posts, the call for donations was put out to staff. We were overwhelmed with the response and repeatedly had to source more and more boxes for all of the supplies we had to donate.

Special thanks goes to the team at Riverside who very kindly donated a huge box full of goodies for us to send on to the foodbank.

We are very grateful for all of the donations made by our generous staff and on behalf of Blackburn foodbank, thank you all very much.



Keep up to date with our company news by following us on:
Twitter (@wecgroup ltd) or Facebook (fb.com/wecgroup ltd)

Christmas at WEC Group

Christmas Jumper Day across WEC Group and HTA

Thank you to everyone who got into the festive spirit and took part in our annual company-wide Christmas Jumper Day on Friday 21st December. Staff across WEC raised money for Galgos Del Sol and everyone at HTA Group supported Myton Hospice. Well done to everyone involved!



Christmas Tree Competition

Well done to WEC Machining for maintaining their title in our annual competition. They chose to donate their £50 prize to Macmillan Cancer Support.

Winners- WEC Machining

WEC Christmas Raffle



Thank you to everyone who bought tickets for this year's Christmas raffle, helping to raise a fantastic sum of £1142.91 for East Lancashire Hospice.

WEC Group Charity of the Year 2019



Fundraising Off to a Flying Start

Our fundraising for our new Charity of the Year is already off to a flying start!



Lisa Cooper and Angela Rutter (pictured left) recently attended an event at the hospice where they presented the charity with a cheque for £1,184.50 in memory of Caroline Turnbull.

Stay tuned for various fundraisers for this great cause throughout the year as we try to make 2019 our best year yet and defeat our £7,464.85 total for 2018.

A big thank you to all those who made donations so far in 2019 and continue to support our fundraising efforts year on year.

Keep up to date with our company news by following us on: Twitter (@wecgroup ltd) or Facebook (fb.com/wecgroup ltd)

Over to you

Bootesylicious Boxing

We would like to congratulate Chris Bootes from our WECJet division for his recent success at his charity boxing match!



The UWCB event took place at Dunkenhalgh Mercure Hotel on 24th March and was in aid of Cancer Research UK.

After completing long and gruelling training, Chris was victorious on the night and managed to raise an incredible £330 through his JustGiving page. Thank you to everyone who donated!

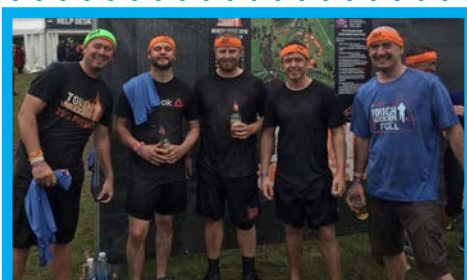

Team WEC 2 - 0 Tough Mudder

This year we had two teams tackle the gruelling Tough Mudder Challenge. Congratulations to Tom Woodburn, Will Barr, Jonny Holding, Josh Wickers and John Scoular. (pictured above)

Congratulations also to Chris Bootes, Ryan Hindle, Alan Gore and Paul Wilson who also took on the course and supported Oliver's Neuroblastoma Appeal.



NO-vember

Well done to WECJet and Laser Manager, Gareth Taylor and our Commercial Director, Wayne Wild for successfully completing their dry November in support of East Lancs Hospice. They managed to raise an impressive £3,762.



Nash's Charity Skydive

Well done to Karl (Nash) Parrington from our Laser division who completed a charity skydive from 15,000ft at Black Knights Parachute Centre in October.

Nash braved the jump in memory of his late mother and all proceeds went to the East Lancashire Hospice.

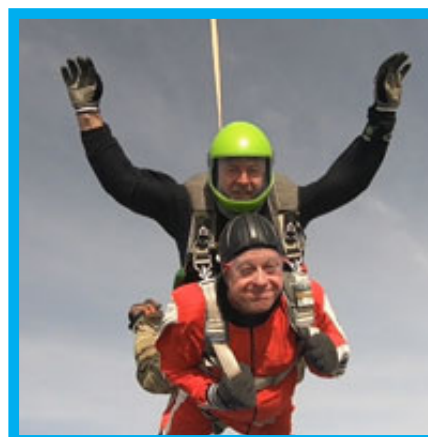

Apprentice Hero

After witnessing rival and Formula Ford star Nelson Rowe collide at high speed with a fellow competitor in a frightening crash, WEC Group apprentice and Rowe's competitor, Callum Grant, left his own vehicle to rush to Rowe's aid.



Braving the growing flames of Rowe's burning vehicle which was left upside down from the impact, Callum flipped Rowe's car upright and assisted in his rescue.

Incredibly, Callum then went on to finish the race in second place.

It's a Girl!!

On Friday 12 April at 2:42am, Tony from our 5750 Components welcomed his first child and beautiful little girl to the world, Lara May Gormley.

WEC Group would like to say a huge congratulations to Tony and his family!



Email your stories and photos to info@wecl.co.uk to be a part of our next issue

Getting to Know...



Gemma Kennedy

HR Manager

How long have you worked at WEC?

I started in December 2012 and so I have worked for WEC for just over 6 years

As a child, what did you want to be when you grew up?

I used to want to be a primary school teacher. I really wanted to help young children learn and all the school holidays I would get seemed very appealing.

What do you enjoy doing in your spare time?

As a busy mum to 2 young children, I don't have a lot of spare time but when I get the chance I like spending my

spare time with my friends and family. I like visiting new places and going out for food and drinks!

What is your favourite film?

I really enjoy watching films, it's difficult to pick just one. My Top 3 would be Back to the Future, The Notebook, and One Flew Over The Cuckoo's Nest.

What makes you smile?

When my 4 year old daughter tells me she loves me and that I'm the best mummy ever. Also, when I walk through the door after work and they both run up to me with big smiles on their faces and throw their arms around me.

What's your favourite holiday getaway?

It has got to be Greece. If I had to pick just one of the Islands I would probably say Zante is my favourite.

Who do you admire the most?

This has to be my Mum and Dad! They are my inspiration.

What super power would you have?

Telepathy. I'd want to be able to read people's minds and know what they are thinking.

What is your favourite food?

A medium rare steak with peppercorn sauce, with a large glass of rioja on the side.

What's the craziest thing you've ever done?

I worked as a Holiday Rep in Majorca for 9 months when I

was younger - that was pretty crazy.

If you could meet someone living or dead, who would it be?

I would want to meet Princess Diana.

Who is your favourite singer?

Whitney Houston, I could listen to her songs all day.

What is your greatest achievement to date?

Being a Mum to 2 amazing children.

Best piece of advice you've ever received?

Be kind to people; treat people as you would like to be treated.

What would you say is the highlight of your time at WEC Group?

My highlight is probably being able to introduce staff benefits for everyone such as the company-funded healthcare cashback scheme that we run.



Recommend a friend to join our workforce and you can earn **£1,000!**

You will get £250 after their first 3 months with the Company and a further £750 once they have been employed for 12 months.

Contact HR or check the intranet for more information